

INBOARD SPRING MODELS • OUTBOARD SPRING MODELS • GAS SPRING MODELS • TOP MOUNT MODELS • SPECIAL DESIGNS



Milfab[®]
Cam Punch Units

Pos-Z-Cam

Make long-term die reliability a reality!

The Milfab Pos-Z-Cam is a powerful compact positive return cam designed to maximize die runtime.

FEATURES:

- Large working ratings from 5-15 Tons (44-133kN)
- Option to mount on any angle up to 15 degrees (specify angle when ordering)
- Choice of hard inch or hard metric dowels, screws and keyways
- Ball lock punch retainment holds round and shaped punches

Milfact:

Milfab Cam Units use investment cast hardened steel components which guarantees consistency, performance, and designed for long life.

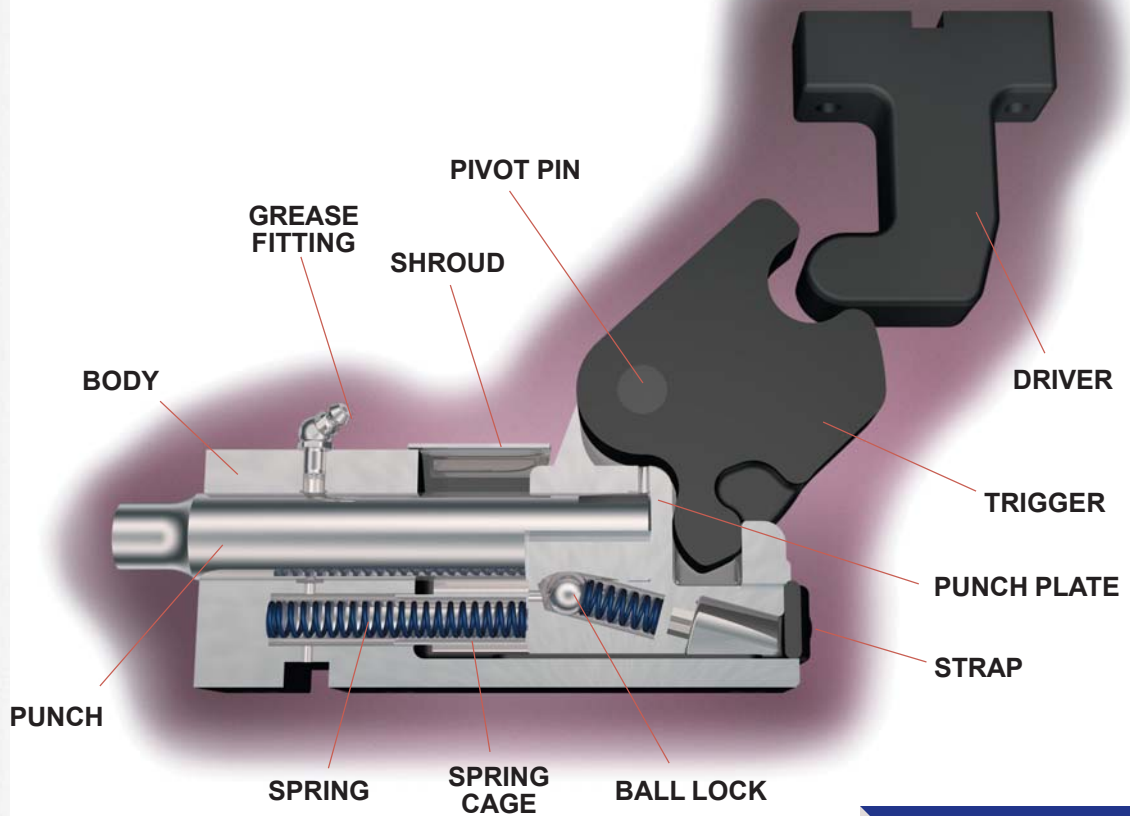

Milfact:

Pos-Z-Cam's 100% interchangeable components provide unsurpassed accuracy and precision.

FEATURES:

- Large mounting face easily accepts punch retainer or other custom tooling
- Case hardened slide with graphite inserts provide long lasting self lubrication
- Option to mount on any angle up to 15 degrees (specify angle when ordering)

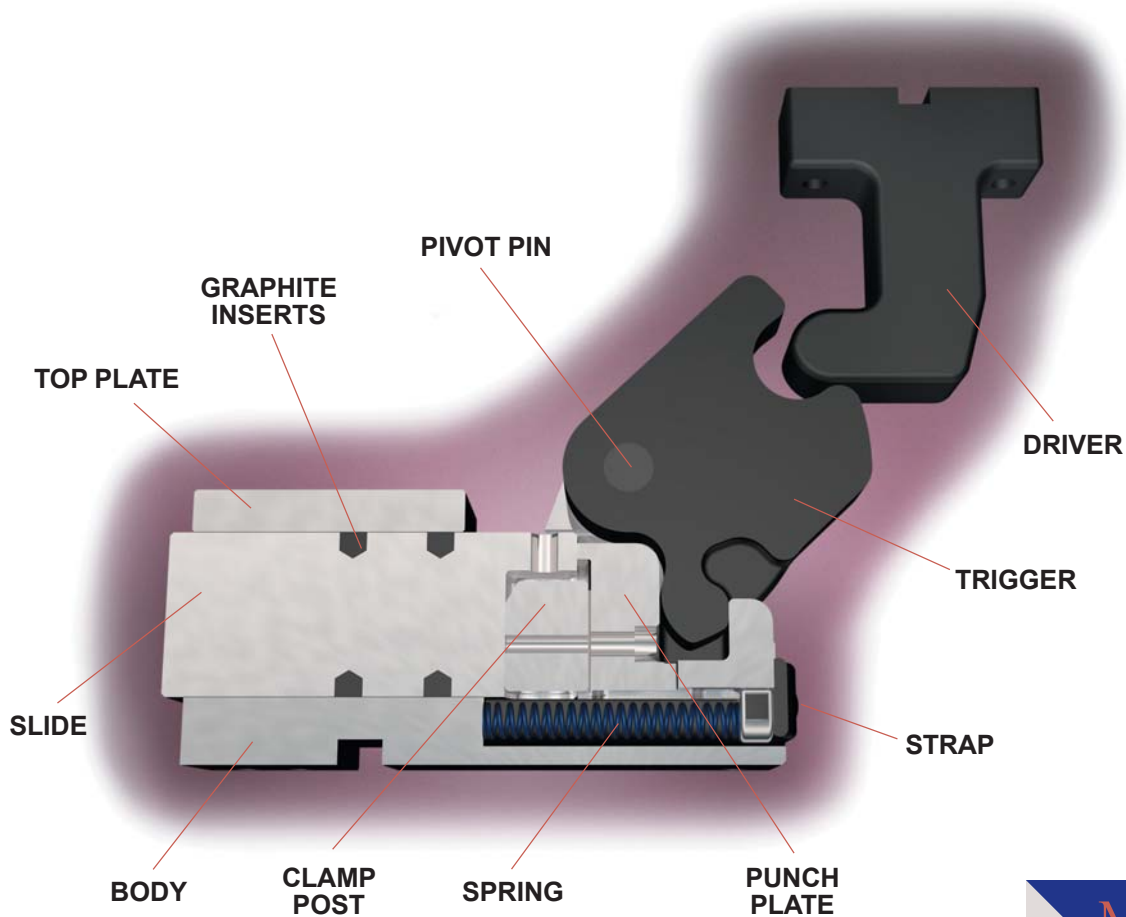
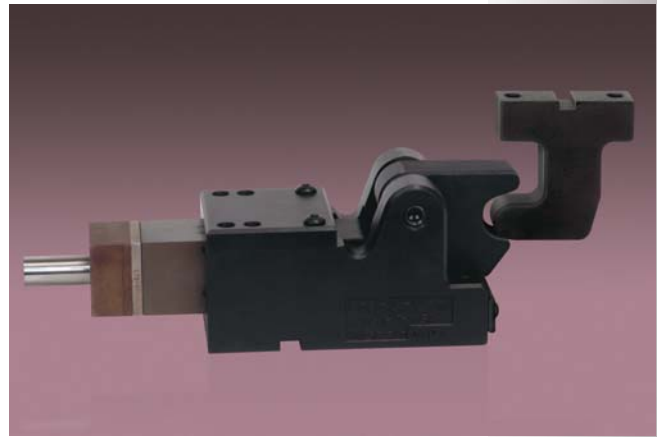

Milfab Cam Units are in stock for quick delivery and are backed by outstanding service and support!

Milfact:

The face of the Pos-Z-Cam R-187 is soft for easy mounting of a punch retainer.

FEATURES:

- Urethane stripper and steel washer mounted on punch tip
- Internal light-duty compression spring for unit reset
- Use on flat surfaces with room for stripper displacement
- Maximum point size is less than the punch diameter
- Most compact size

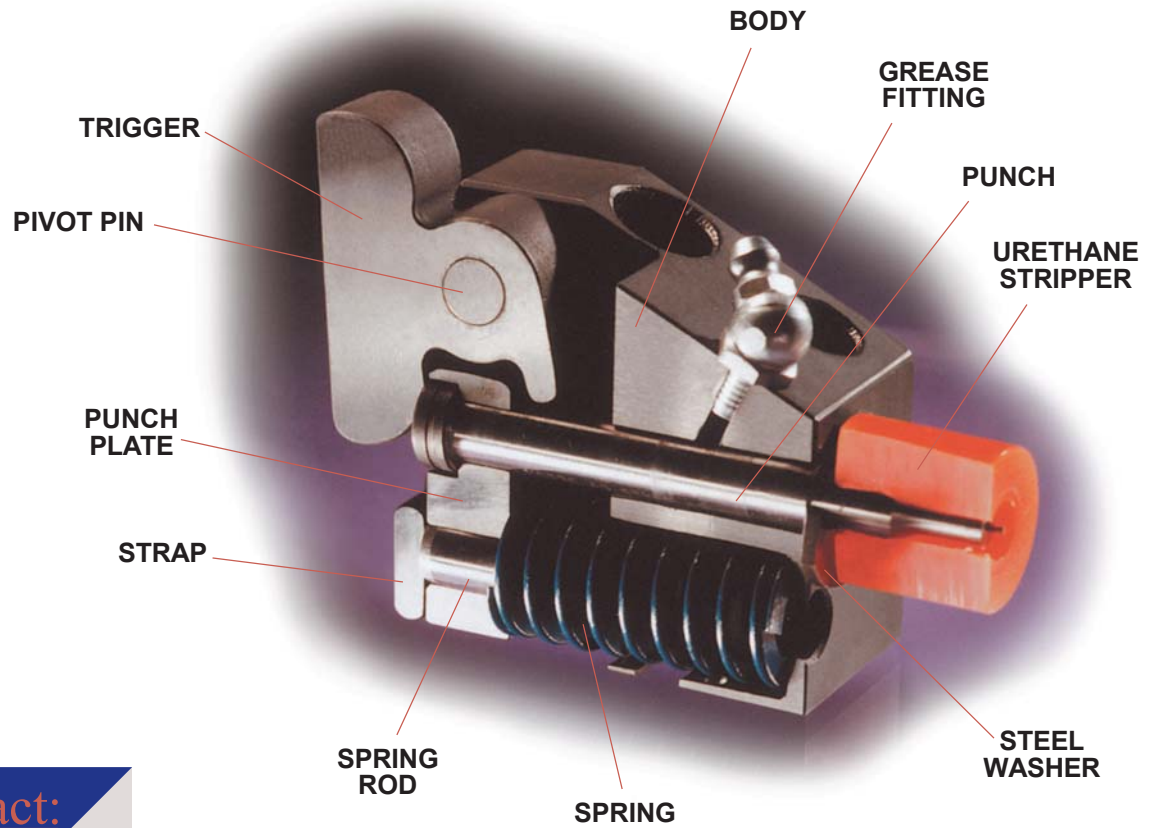

Milfact:

Milfab's unique rotary trigger translates the ram's vertical motion to horizontal motion.

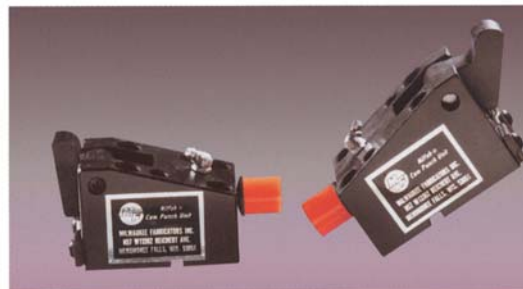

Milfact:

Use the standard trigger with a spring return cam unit mounted from horizontal to 15° and an offset trigger when mounted 15° to 60°.

FEATURES:

- External heavy-duty die spring for stripping and unit reset
- Use on curved surfaces or tubes
- Part must be held for stripping to occur. Use horn, mandrel, etc.

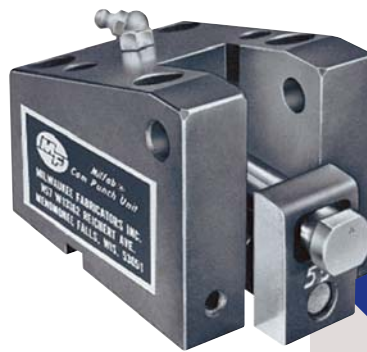
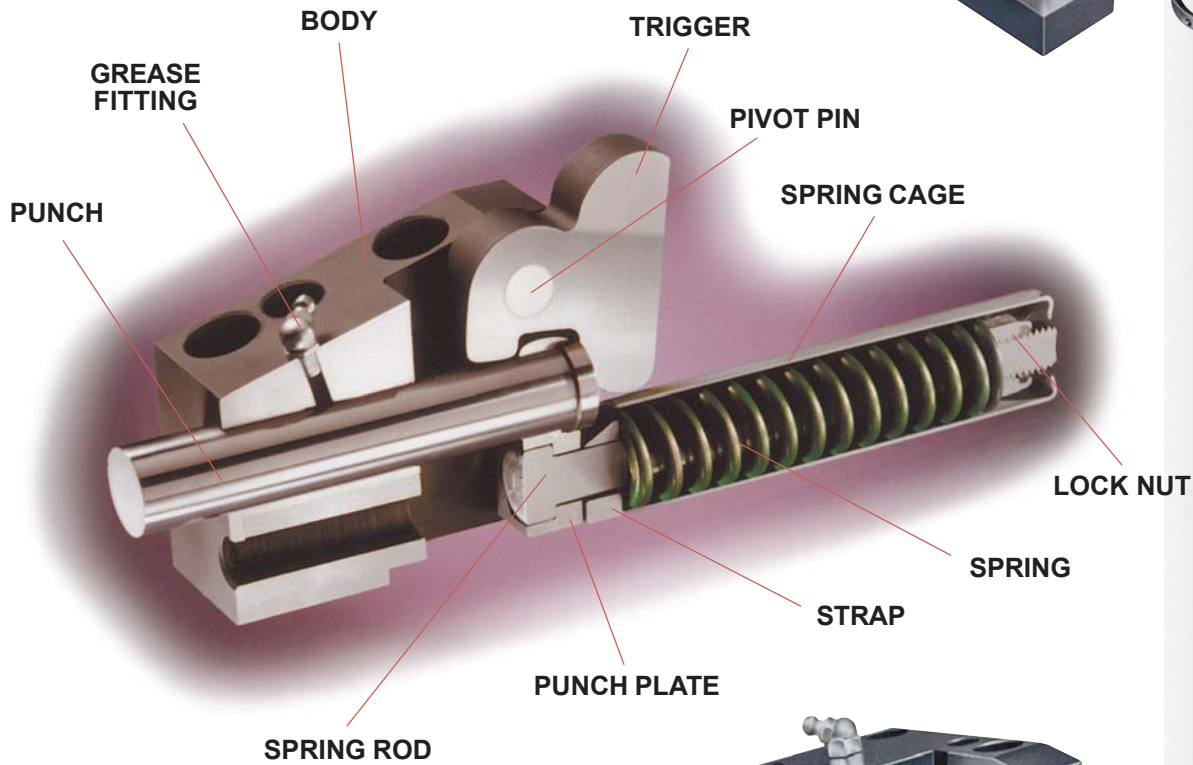
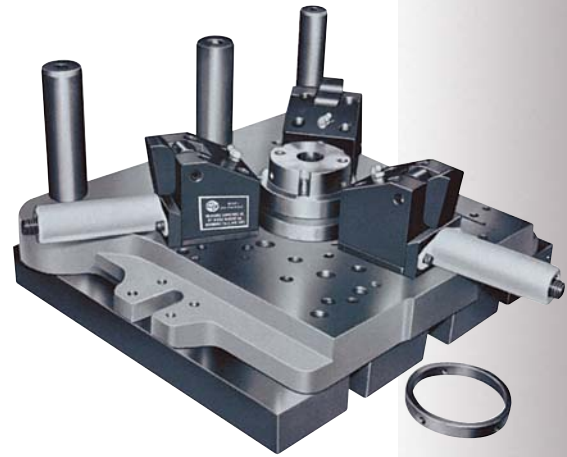

Milfact:

Keyed Cam Units have a dual flatted punch head keyed to the punch plate, which is mated to the body.

FEATURES:

- Ultra-high stripping forces
- External heavy-duty die spring aids stripping and resets unit
- Gas spring engages at stroke's end
- Use where large holes or thick, sticky material require large stripping forces
- Gas Spring Models are the same size as Outboard Spring Models

Milfact:

All Milfab Cam Units include a keyway in the mounting surface to absorb the punching force.

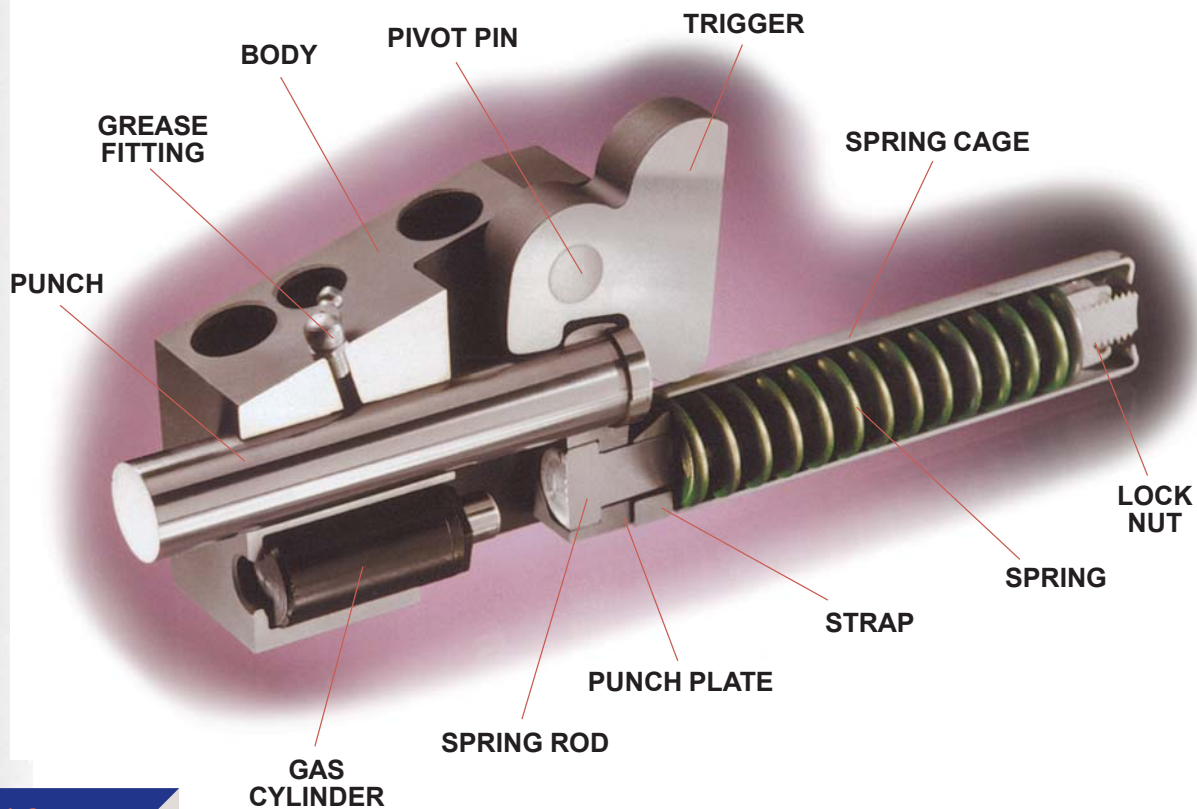

Milfact:

Tight punch-to-bore tolerance on all cam units and punch-plate-to-body tolerance on keyed units assure accurate motion.

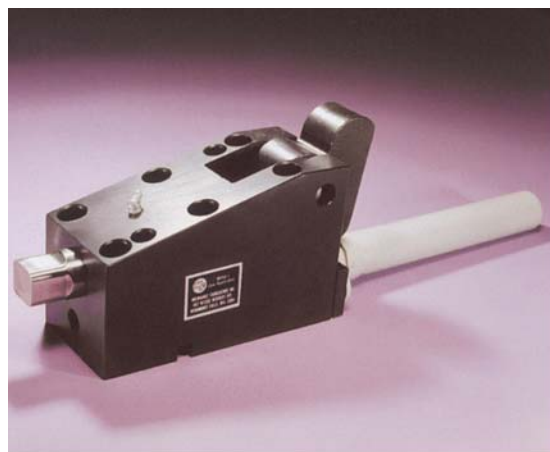

FEATURES:

- Standard Inboard, Outboard and Gas Spring Models in special Top Mount bodies
- Mount to a fixed top plate or spring-loaded top die plate
- Oil impregnated bronze bearings are standard on all Top Mount Models

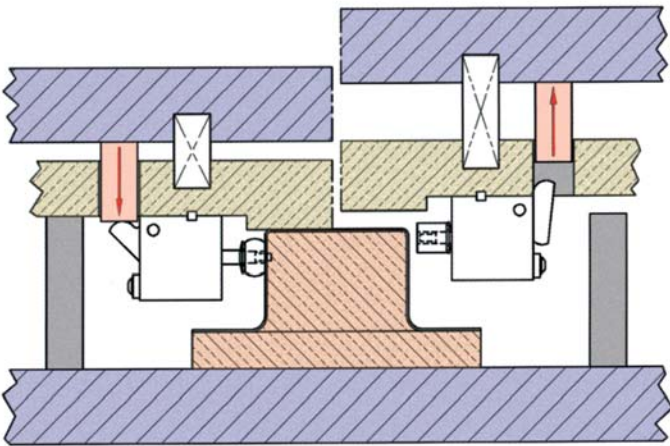

Standard Trigger

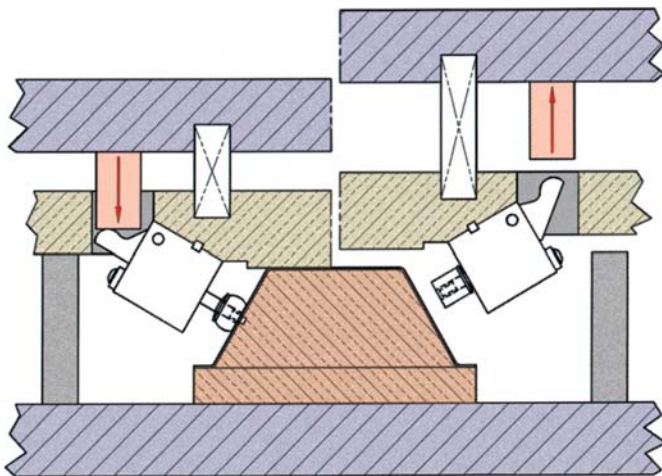

Offset Trigger

Milfact:

All Milfab models are available with oil-impregnated

bronze bearings.



COMMON USES:

- In progressive dies for a clear coil path between strokes
- To punch from inside the part
- In-die punching in forming dies after the surface is formed
- Punching surface is only accessible from above
- To reach over large flanges
- Where a bottom die mounted cam unit interferes with the part

CHOOSE THE RIGHT STYLE

SEVEN POINT SELECTION GUIDELINES

- 1. Material Thickness.** Do not exceed the rated material thickness for each cam unit without consulting our engineering department.
- 2. Part Shape.** Use the Pos-Z-Cams where positive stripping is required. Use Inboard Spring cam units on flat parts with room for urethane stripper displacement. Use Outboard Spring cam units on tubes and cured surfaces for positive die spring stripping. Use Gas Spring cam units where higher stripping force is required.
- 3. Punch Stroke.** Select amount needed. Use full stroke for maximum leverage and stripping force.
- 4. Punching Force.** Punching Force, tons = $LC \times t \times TS \div 2000$
- 5. Stripping Force.** The force required to strip a punch is difficult to determine since it is influenced by the type of metal pierced, punch size, punch/die clearance, punch sharpness, and other factors.

$$\text{Stripping Force, lbs.} = LC \times t \times M \times 2000$$

Where: LC = Length of cut (hole circumference, hole perimeter, notch length, etc.)
 t = Material thickness
 TS = Material tensile strength, psi
 M = Material multiplier, tsi, steel and stainless steel – 1.5, aluminum – 2.25

- 6. Point Size.** Diagonals must fit maximum point size. For Inboard Spring models maximum point size is less than punch body diameter due to the ground shoulder supporting the washer and stripper.
- 7. Point Shape.** The Pos-Z-Cam punch points can be either round or shaped with the standard ball lock punch. The spring return cams with shaped points require keyed (k) cam units to keep the punch from rotating in the bore.

Dowels to be transferred to mounting surface at assembly.

Milfab Cam Units generate the rated punching and stripping forces at the end of the stroke. Always use the full stroke entering the die 1/16 in.

HOW TO ORDER

PREFIXES

(Spring Return Model)

(n)	Number of punches
M	Metric punch, dowels, and screws
T	Top mount
G	Gas spring
E	Extended range, oversized point
B	Self-lubricating bushing
K	Keyed cam unit and punch
O	Outboard spring
S	Short punch stroke
L	Long punch stroke
P	Positive Return

SUFFIXES

(Positive & Spring Return Models)

A	A2 punch
AE	A2 ejector punch
M	M2 punch
ME	M2 ejector punch

PUNCH BODY DIAMETER

(Positive & Spring Return Models)

250	1/4 in., 6 mm
375	3/8 in., 10 mm
500	1/2 in., 13 mm
625	5/8 in., 16 mm
75	3/4 in., 20 mm
87	7/8 in. (no metric equivalent)
100	1 in., 25 mm
125	1-1/4 in. (no metric equivalent)
137	1-3/8 in. (no metric equivalent)
150	1-1/2 in. (no metric equivalent)

To order, specify quantity, cam unit model number, and P' dimension for round holes, or P' and W' dimensions and the shape.

Example: KOS125AE, P=.495", W=1.102", oblong. This is a keyed, outboard spring model, short stroke cam unit with a 1.250" A2 ejector punch ground to a .495" x 1.102" oblong point.

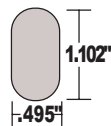

STANDARD ROUND



SQUARE

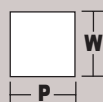

OBLONG

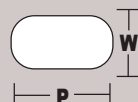

RECTANGULAR

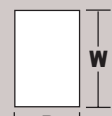
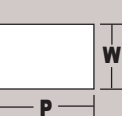

INBOARD SPRING

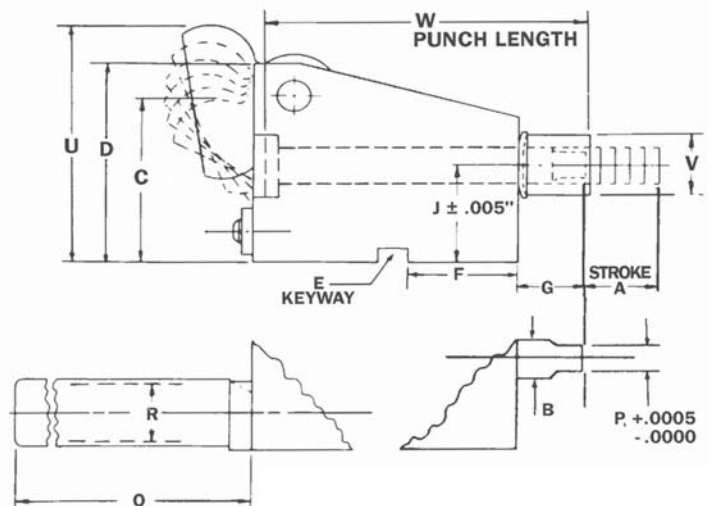
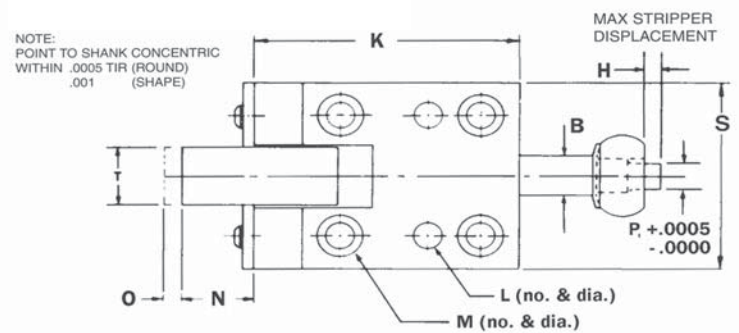

OUTBOARD SPRING & GAS SPRING

INBOARD AND OUTBOARD SPRING SPECIFICATIONS AND DIMENSIONS

Model No.	S250	L250	S375	L375	S500	L500	S625	L625	S75	L75	S87	L87	S100	L100	S125	L125	S137	L137	S150	L150		
Max. material thickness ¹	1/16								1/8								1/4					
tons ²	1.5		3		5		8		15								25					
Stripping force ⁵																						
-Inboard lbs.	370		440		460		570		690		710		1020		1050		1090		1120			
-Outboard lbs.	140		300				540		830								1650					
-Gas Spring lbs.	Not available								1420								4930					
Punch stroke with standard trigger																						
A Stroke	3/8	3/4	1/2	7/8	5/8	1	3/4	1-1/8	1-1/4	2	1-1/4	2	1-1/4	2	1-1/2	2-1/2	1-1/2	2-1/2	1-1/2	2-1/2		
Punch stroke with offset trigger C.N.O.U. Dimension Change with offset trigger																						
A Inboard	3/8	21/32	1/2	47/64	5/8	25/32	3/4	1-1/16	1-7/64	1-1/16	1-7/64	1-1/16	1-7/64	1-1/16	1-1/2	2-1/2	1-1/2	2-1/2	1-1/2	2-1/2		
A Outboard	11/32		1/2	31/64	5/8	21/32	11/16		3/4								1-1/2	2-1/64	1-1/2	2-1/64	1-1/2	2-1/64
B Shank dia. (mm)	.250 (6 mm)		.375 (10 mm)		.500 (13 mm)		.625 (16 mm)		.750 (20 mm)		.875		1.000 (25 mm)		1.250		1.375		1.500			
Max. point dia.																						
-Inboard ^{3,4}	.187		.312		.437		.562		.687		.812		.937		1.125		1.250		1.375			
-Outboard ⁴ (mm)	.250 (6 mm)		.375 (10 mm)		.500 (13 mm)		.625 (16 mm)		.750 (20 mm)		.875		1.000 (25 mm)		1.250		1.375		1.500			
C Shut ht.	1-11/16	1-5/16	2-3/32	1-3/4	2-5/32	1-27/32	2-1/2	2-7/32	3-3/64	2-33/64	3-3/64	2-33/64	3-3/64	2-33/64	5-5/32	4-1/4	5-5/32	4-1/4	5-5/32	4-1/4		
D	1-3/4		2-1/4		2-1/2		3		3-3/4								5-1/2					
E Keyway	3/16 x 3/32		1/4 x 1/8		5/16 x 5/32		3/8 x 3/16		1/2 x 1/4													
F	1/2	1	11/16	1-3/16	13/16	1-1/4	1	1-7/8								2-1/8	2-1/2	2-1/8	2-1/2	2-1/8	2-1/2	
G	7/8								1-1/8								1-5/8					
H	1/4								3/8													
J Inboard	.812		1.125		1.187		1.500		1.812								2.625					
J Outboard	.812		1.125		1.187		1.500		1.812		1.750		1.687		2.625							
J Gas Spring	Not Available								1.812								2.625					
K	1-3/4	2-3/4	2-1/4	3-1/4	2-1/2	3-1/2	3	4	4-1/2	6-1/2	4-1/2	6-1/2	4-1/2	6-1/2	6	8-1/2	6	8-1/2	6	8-1/2		
L (No.) & dia. (mm)	(2) 1/4 (6 mm)		(2) 5/16 (8 mm)				(2) 3/8 (10 mm)		(2) 1/2 (16 mm)													
M (No.) & dia. (mm)	(2) 1/4 (6 mm)	(4) 1/4 (6 mm)	(2) 5/16 (8 mm)	(4) 5/16 (8 mm)	(2) 5/16 (8 mm)	(4) 5/16 (8 mm)	(2) 3/8 (10 mm)	(4) 3/8 (10 mm)	(4) 1/2 (14 mm)	(6) 1/2 (14 mm)	(4) 1/2 (14 mm)	(6) 1/2 (14 mm)	(4) 1/2 (14 mm)	(6) 1/2 (14 mm)	(4) 1/2 (14 mm)	(6) 1/2 (14 mm)	(4) 1/2 (14 mm)	(6) 1/2 (14 mm)	(4) 1/2 (14 mm)	(6) 1/2 (14 mm)		
N	13/32		35/64				57/64		1-9/64								1-27/32					
O	17/64		1/4				13/64		11/32								7/16					
Q	2-7/8	4-1/8	3-7/8	5-3/8	4-3/8	5-7/8	4-7/8	6-3/8	9-3/8	6-3/8	9-3/8	6-3/8	9-3/8	7-1/2	11-1/2	7-1/2	11-1/2	7-1/2	11-1/2			
R	5/8		3/4				1		1-1/4								1-1/2					
S	1-3/4		2-1/4		2-1/2		3		3-1/2								4					
T	5/8		3/4		7/8		1		1-1/8								1-5/8					
U	2-5/32		2-21/32		2-55/64		3-13/32		4-29/64								6-11/16					
V	.687		.812		.875		1.000		1.125		1.375		1.625		1.875		2.125		2.375			
W	2-1/2	3-1/2	3	4	3-1/4	4-1/4	3-3/4	4-3/4	5-1/2	7-1/2	5-1/2	7-1/2	5-1/2	7-1/2	10	7-1/2	10	7-1/2	10			
Model No.	S250	L250	S375	L375	S500	L500	S625	L625	S75	L75	S87	L87	S100	L100	S125	L125	S137	L137	S150	L150		

1. Based on punching mild steel.
 2. Rated tonnage at the end of the stroke.
 3. Maximum inboard point diameter is less than punch shank diameter due to step required for washer and urethane stripper.
 4. The diagonal of shaped punch points must be less than the maximum point diameter.
 5. Stripping forces are calculated at the end of stroke.

Dimensions are in inches, except as noted. Specifications subject to change without notice. Manufactured in U.S.A.

POS-Z-CAM SPECIFICATIONS AND DIMENSIONS

MODEL NO.	P500		P750		P100		R187	
	INCH	METRIC	INCH	METRIC	INCH	METRIC	INCH	METRIC
Maximum Material Thickness¹	1/8		1/8		3/16		3/16	
Max Work in Load (tons/kN)²	5	44	8	71	15	133	15	133
Punch Stroke								
S	1.00	25.40	1.13	28.57	1.25	31.75	1.25	31.75
Point Diameter								
Z Diameter³	.500	13.00	.750	20.00	1.000	25.00	1.875 sq.	48 sq.
A	5.13	130.17	5.75	146.05	6.75	171.45	6.75	171.45
B	4.75	120.65	5.38	136.52	6.25	158.75	6.25	158.75
C	3.63	92.07	3.88	98.42	4.63	117.47	5.635	142.88
D	.38	9.52	.38	9.52	.50	12.70	.50	12.70
E	1.75	44.45	2.00	50.80	2.25	57.15	2.25	57.15
F	.21	5.38	.50	12.70	.50	12.70	.50	12.70
G	.64	16.70	1.13	28.60	.91	20.90	.25	6.40
H	2.50	63.50	3.00	76.20	3.50	88.90	3.50	88.90
I	1.88	47.62	2.25	57.15	2.63	66.68	2.63	66.68
J	1.187	30.150	1.500	38.100	1.688	42.875	.750	18.860
K	.31	7.95	.38	9.52	.44	11.11	.44	11.11
L	5.38	136.52	6.13	155.57	7.13	180.97	6.38	161.92
M	2.38	60.32	2.88	73.02	3.38	85.72	3.38	85.72
N Keyway	5/16 x 5/32	10 x 5	3/8 x 3/16	10 x 5	1/2 x 1/4	16 x 8	1/4 x 1/2	16 x 8
O Keyway	1/4 x 9/64	6 x 3	5/16 x 5/32	8 x 4	3/8 x 3/16	10 x 5	3/8 x 3/16	10 x 5
P	4.25	107.95	4.63	117.47	5.50	139.70	4.75	120.65
Q	1.25	31.75	1.50	38.10	1.75	44.45	NA	NA
R	4.00	101.60	4.75	120.65	6.00	152.40	6.00	152.40
T	.75	11.43	.88	22.22	1.13	28.57	1.13	28.57
U	2.25	57.15	2.63	66.67	3.00	76.20	3.00	76.20
V	1.09	27.61	1.31	33.35	1.50	38.10	1.50	38.10
W (No.) & Dia.	(4) 1/4	(4) 8MM	(4) 5/16	(4) 8MM	(4) 3/8	(4) 10MM	(4) 3/8	(4) 10MM
X (No.) & Dia.	(2) 5/16	(2) 8MM	(2) 5/16	(2) 8MM	(2) 3/8	(2) 10MM	(2) 3/8	(2) 10MM
Y (No.) & Dia.	(2) 1/4	(2) 6MM	(2) 5/16	(2) 8MM	(2) 3/8	(2) 10MM	(2) 3/8	(2) 10MM

¹ Based on punching mild steel.

² Rated tonnage at the end of the stroke.

³ The diagonal of shaped punch points must be less than the maximum point diameter.

Specifications subject to change without notice.

Manufactured in U.S.A.

PIERCE CAM

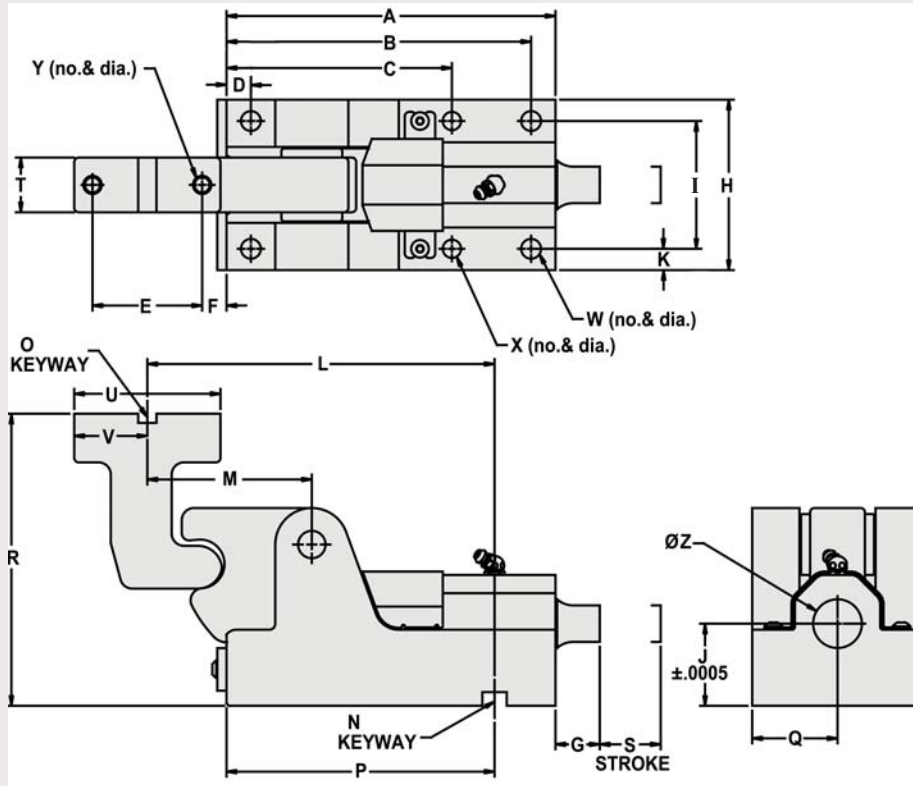

RETAINER CAM

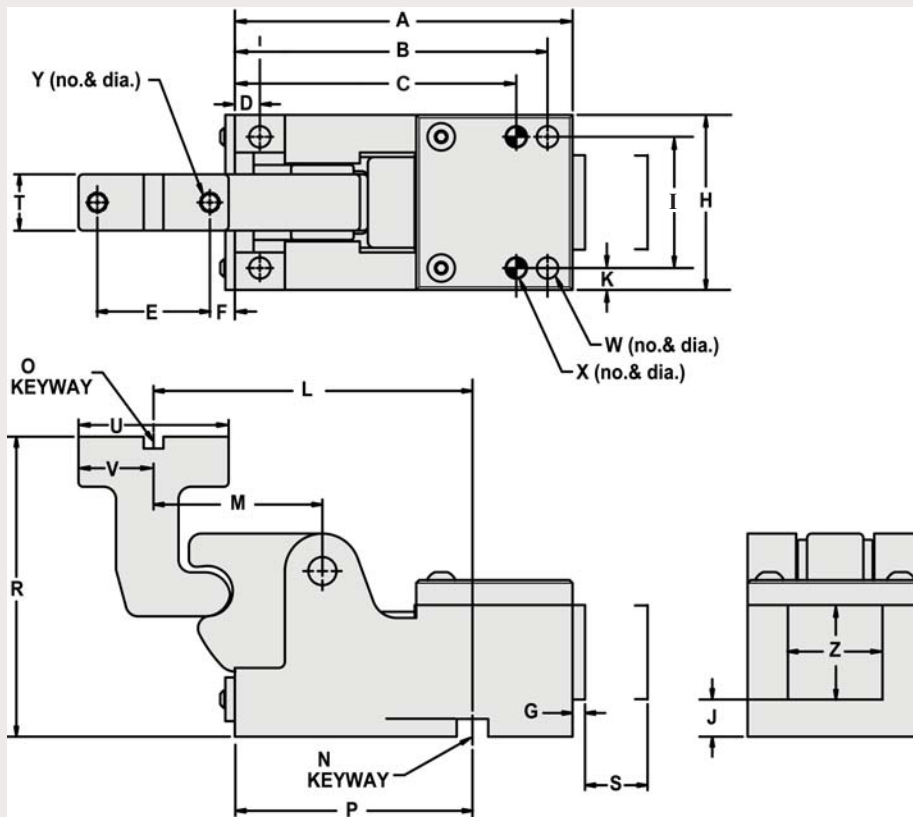

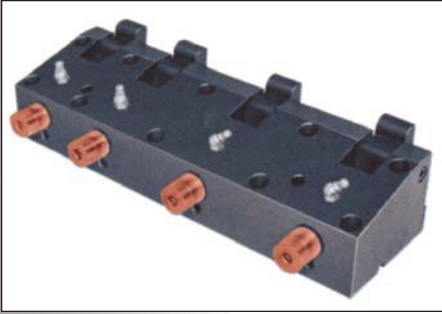

DESIGN A

Four punches on a common horizontal centerline in an inboard cam unit.



DESIGN B

Outboard style cam unit with a punch point larger than the punch body.



DESIGN C

Only the gas spring model can generate high enough stripping force to retract the oversized point from thick, sticky aluminum.

Send us full specifications and drawings for prompt recommendation and quotation.



DESIGN D

Two punches on a large, common vertical centerline. To assure smooth motion and prevent side loads, two triggers are used, one below and behind the other.



DESIGN E

Two punches on a small, common vertical centerline. Using a larger body size, one trigger can safely drive both punches.



DESIGN F

Three punches driven by two triggers. Each punch has a unique horizontal and vertical centerline.



DISTRIBUTED BY:

Milwaukee Fabricators, Inc. www.milfab.com
 N57 W13362 Reichert Avenue
 Menomonee Falls, Wisconsin 53051
 Business Phone: (262) 781-3190
 Business Fax: (262) 781-6658
 Email: sales@milfab.com
 Sales Number: 1-888-MILFAB-1 (1888-645-3221)

©2007 Milwaukee Fabricators, Inc.
 All Rights Reserved

FORM 197-A REV 1/07